



Model 5V3

DATA SHEET

NET WEIGHT 214kg (472lbs)
SHIPPING WEIGHTS 225kg (497lbs)
IMPELLER DIA. 279,4mm (11")
R.P.M. FROM 850rpm TO 2150rpm
MAX. SOLIDS 20.63mm (13/16")

SELF-PRIMING

850 RPM 2,3m (7ft) - 1150 RPM 2,9m (9ft)
 1450 RPM 4,5m (15ft) - 1750 RPM 7,6m (25ft)
 1950 RPM 7,6m (25ft) - 2150 RPM 7,6m (25ft)

BEFORE USING THIS TABLE, CHECK THE NPSH.

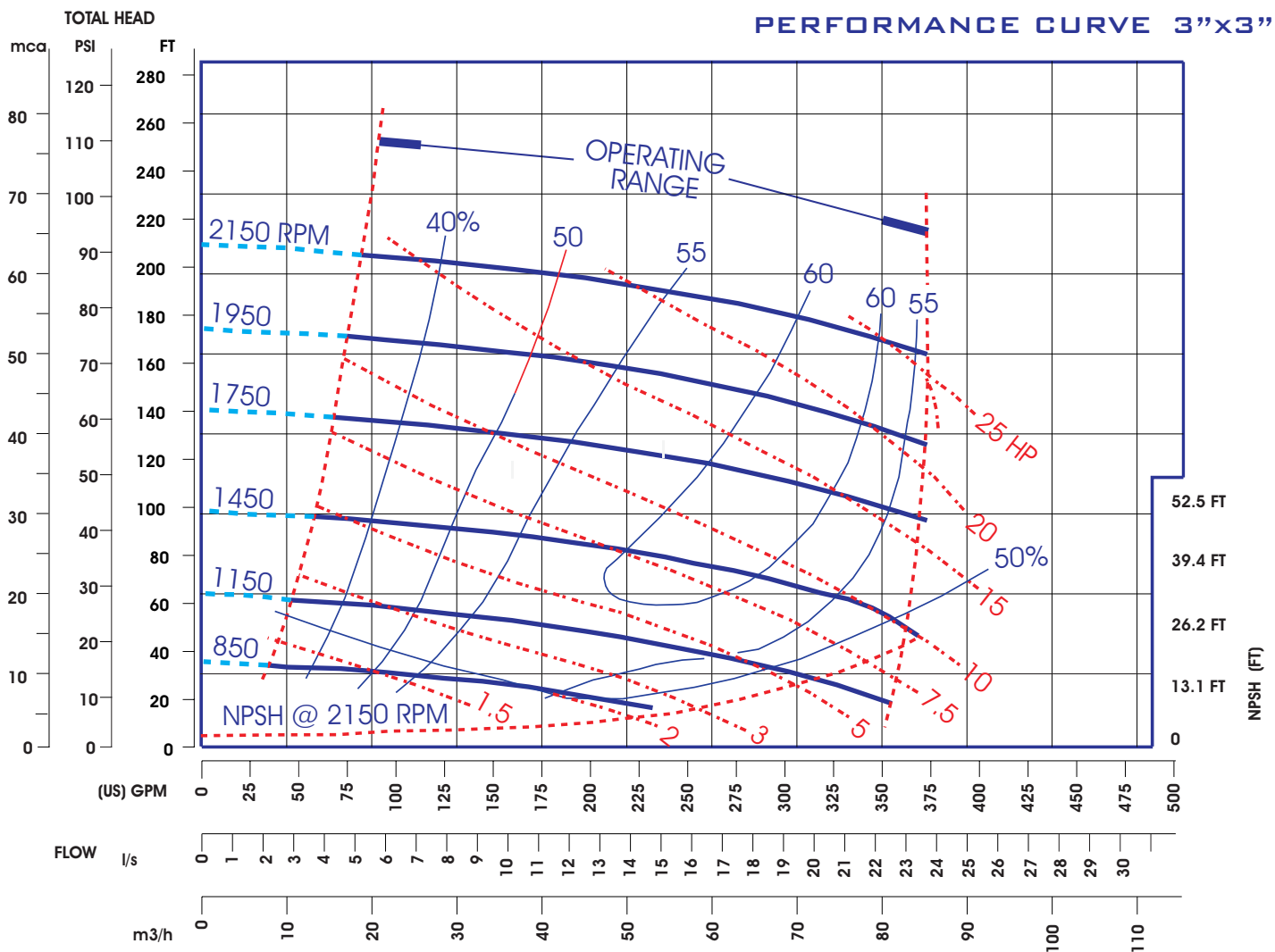



Model 5V4



DATA SHEET

NET WEIGHT 272kg (600lbs)
SHIPPING WEIGHTS 297kg (655lbs)
IMPELLER DIA. 279,4mm (11")
R.P.M. FROM 850rpm TO 2150rpm
MAX. SOLIDS 28.57mm (1.1/8")

SELF-PRIMING

850 RPM 2,4m (8ft) - 1150 RPM 3,0m (10ft)
 1450 RPM 3,6m (12ft) - 1750 RPM 3,9m (13ft)
 1950 RPM 4,5m (15ft) - 2150 RPM 5,2m (17ft)

BEFORE USING THIS TABLE, CHECK THE NPSH.

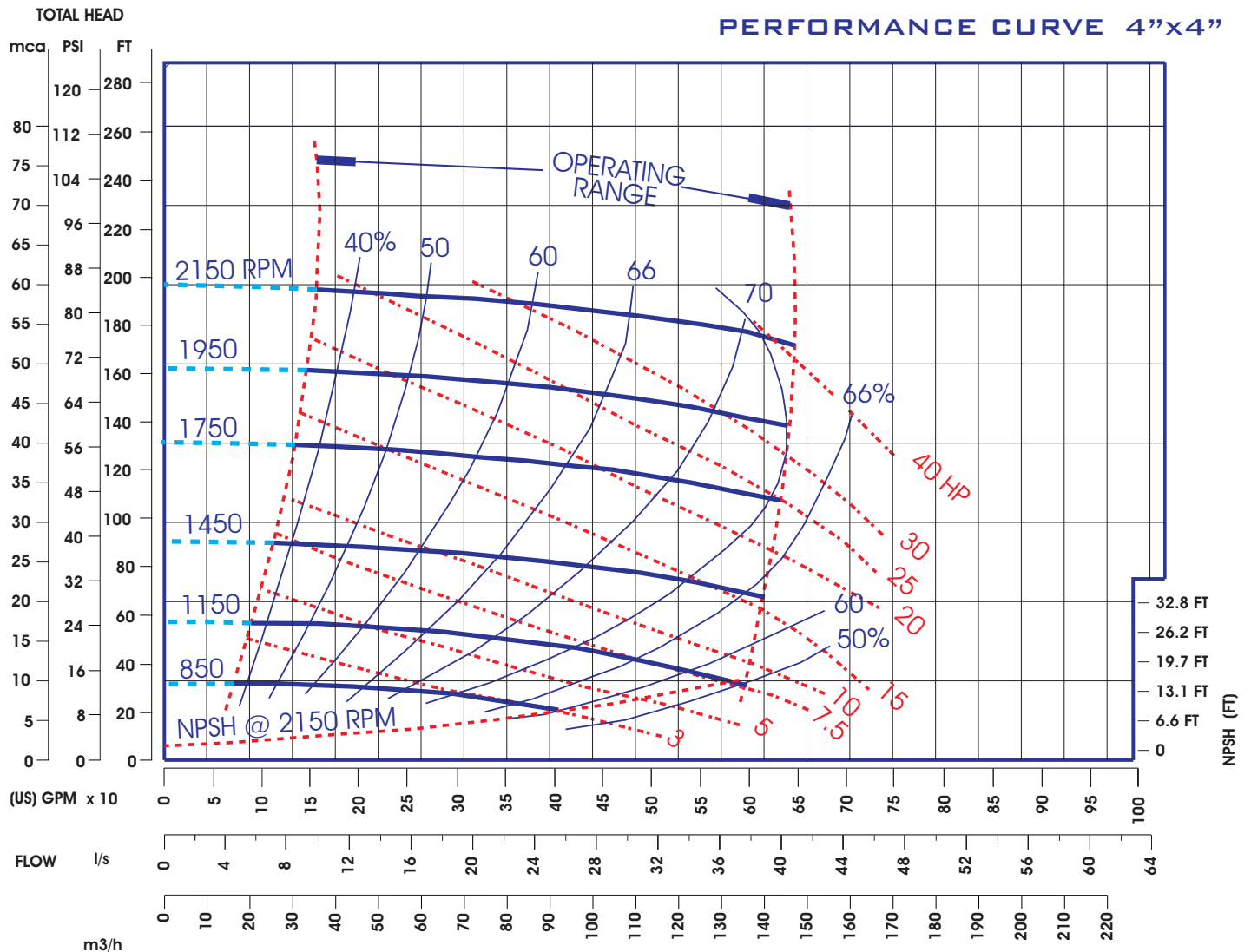



Model 5V4

EXTERNAL DIMENSIONS MILLIMETERS (INCHES)

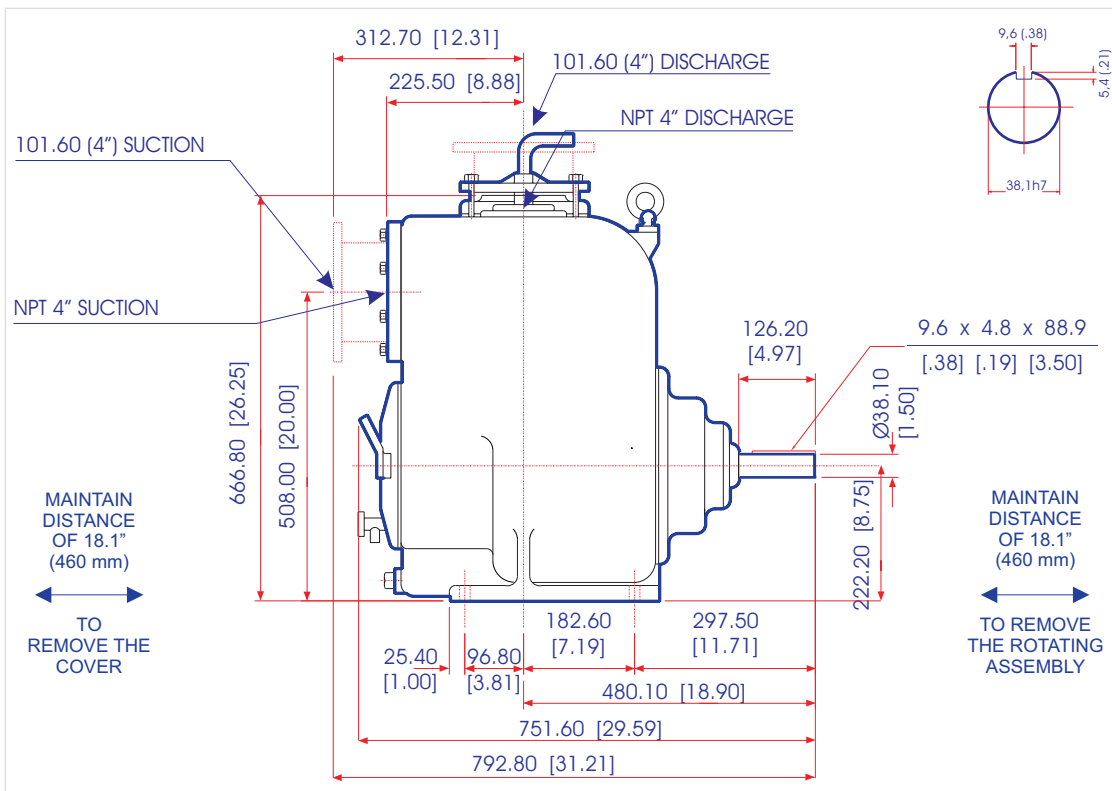
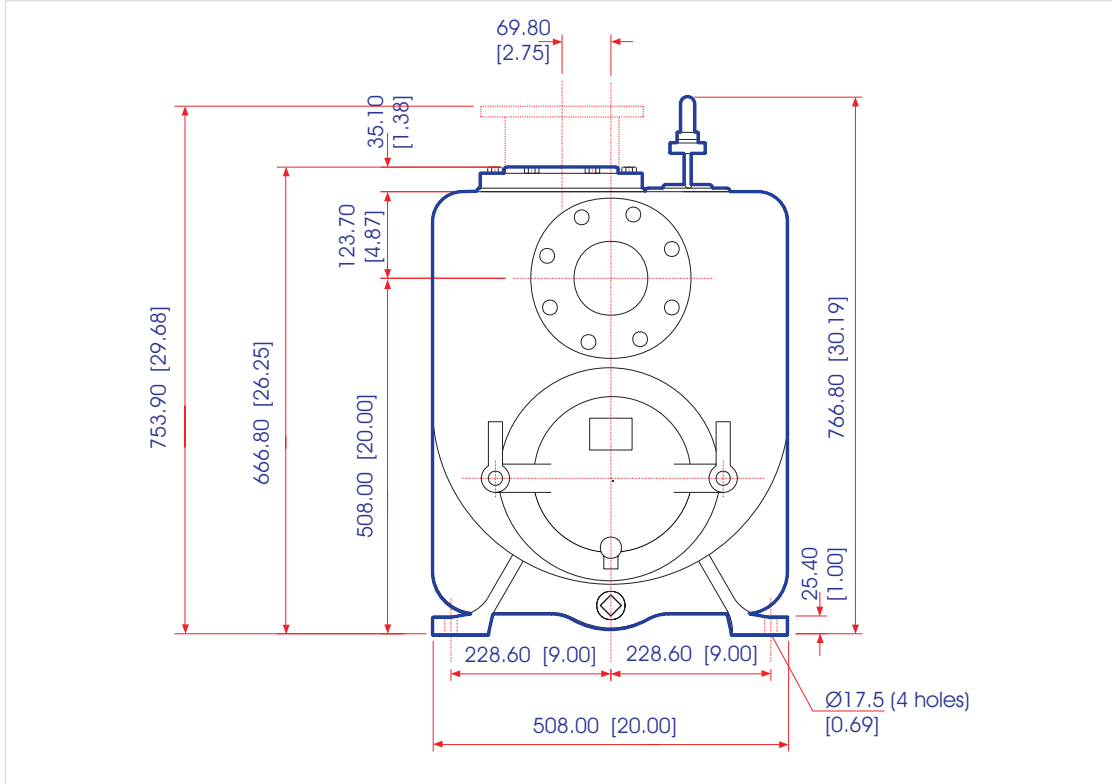



Model 5V6

DATA SHEET

NET WEIGHT 413kg (910lbs)
SHIPPING WEIGHTS 437kg (965lbs)
IMPELLER DIA. 317,5mm (12.1/2")
R.P.M. FROM 850rpm TO 1950rpm
MAX. SOLIDS 31,75mm (1.1/4")

SELF-PRIMING

850 RPM 2,4m (8ft) - 1150 RPM 3,0m (10ft)
 1450 RPM 4,2m (10ft) - 1750 RPM 4,5m (15ft)
 1950 RPM 4,5m (15ft)

BEFORE USING THIS TABLE, CHECK THE NPSH.

PERFORMANCE CURVE 6"x6"

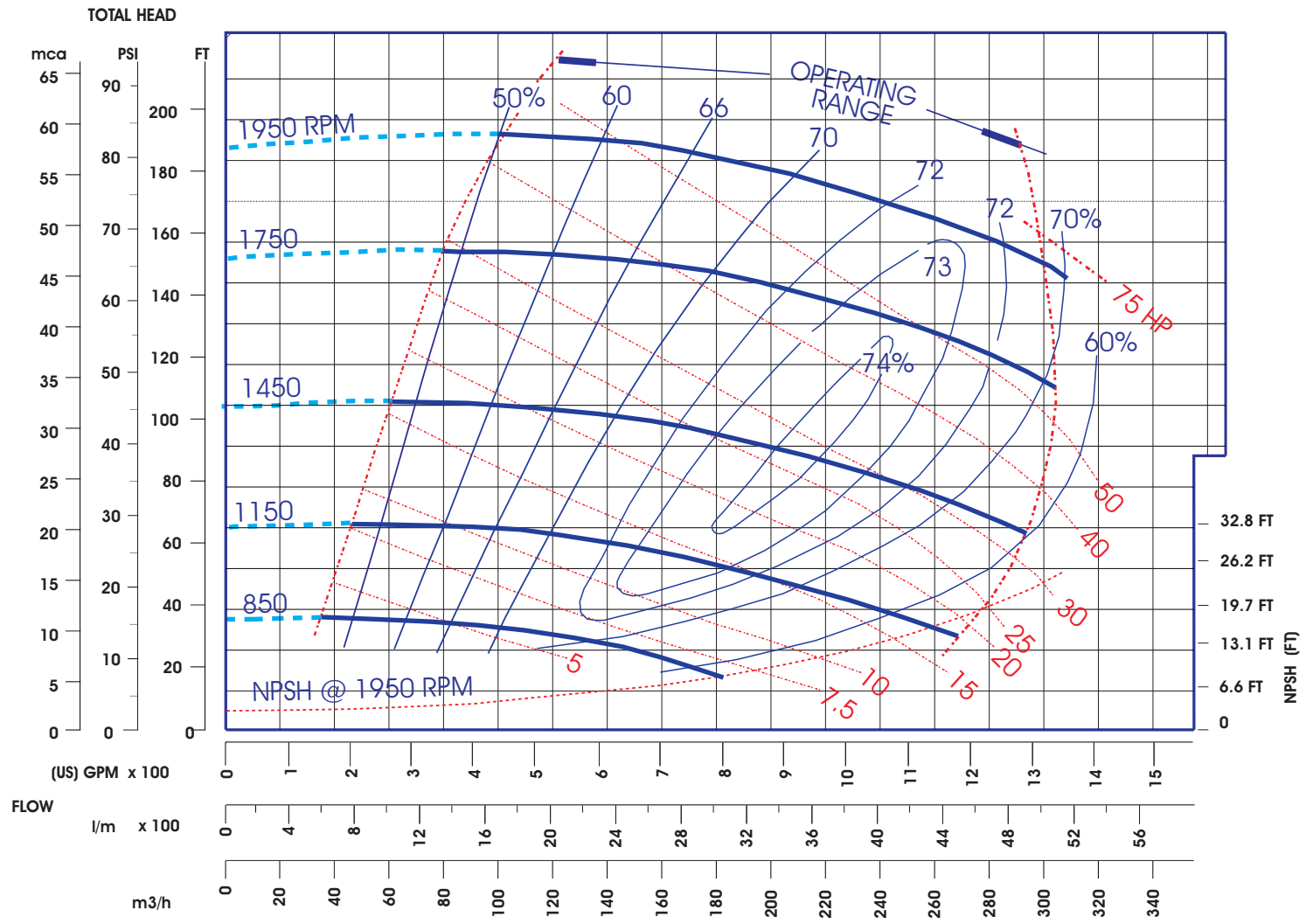

EXTERNAL DIMENSIONS MILLIMETERS (INCHES)

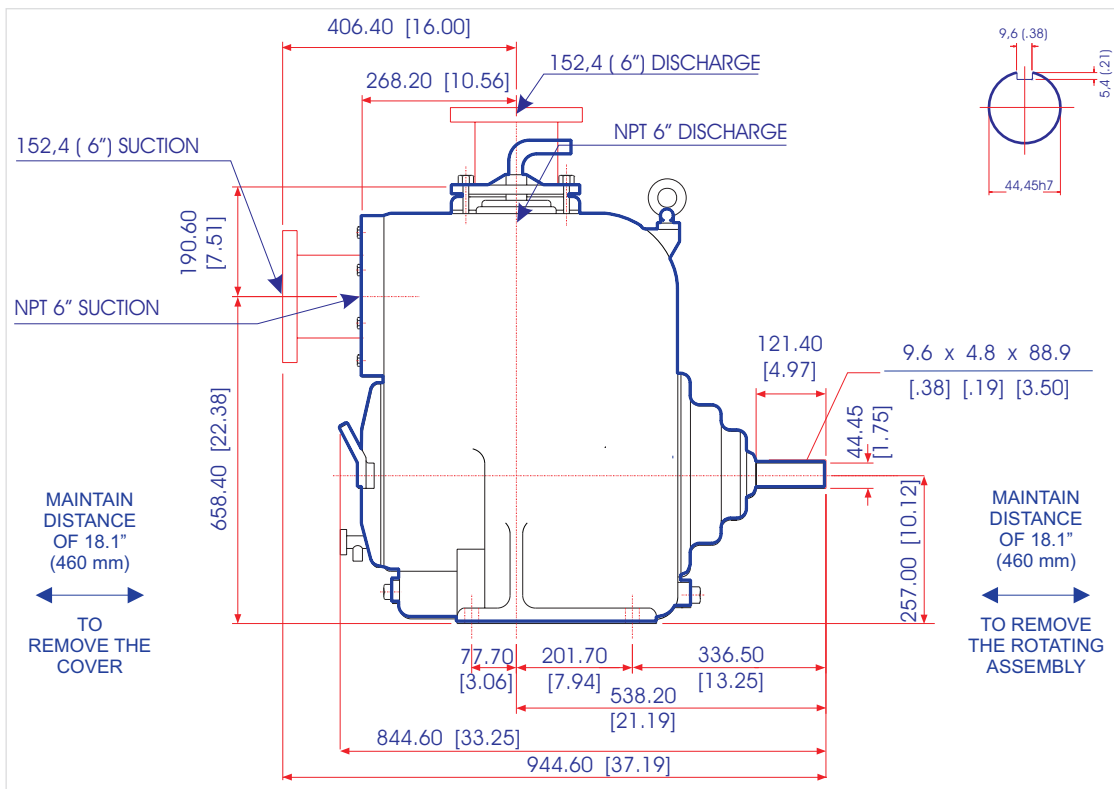
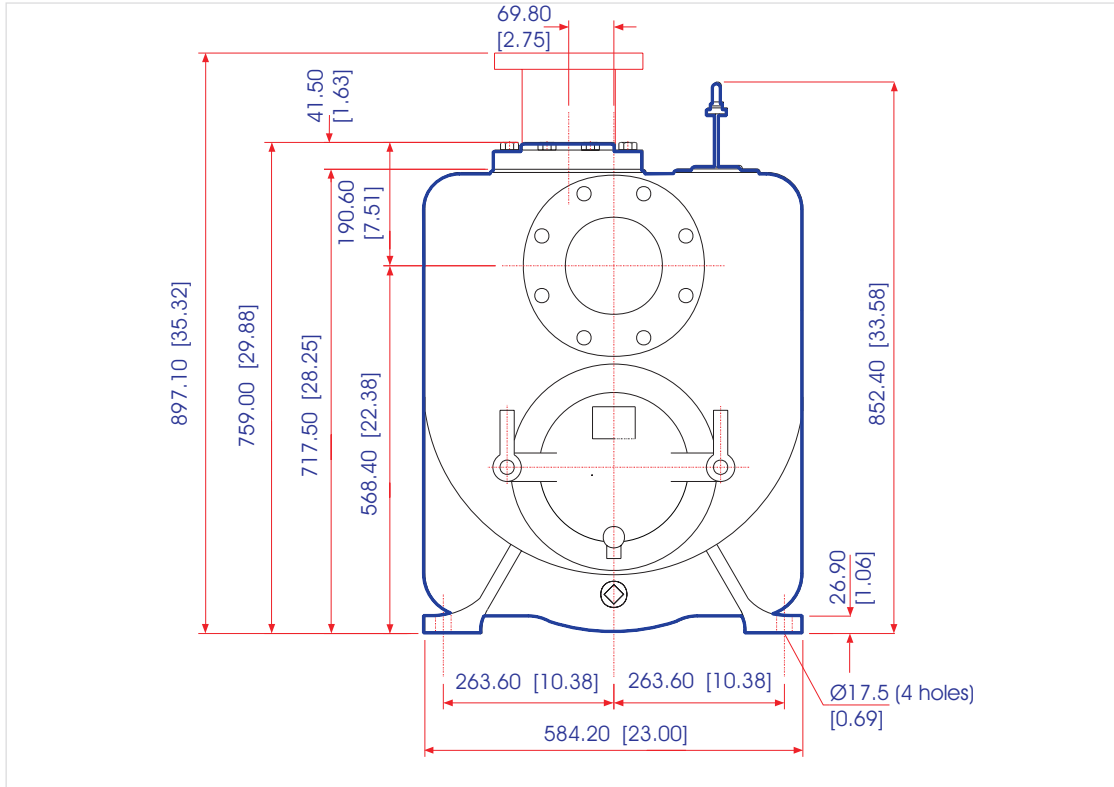

Lift Station

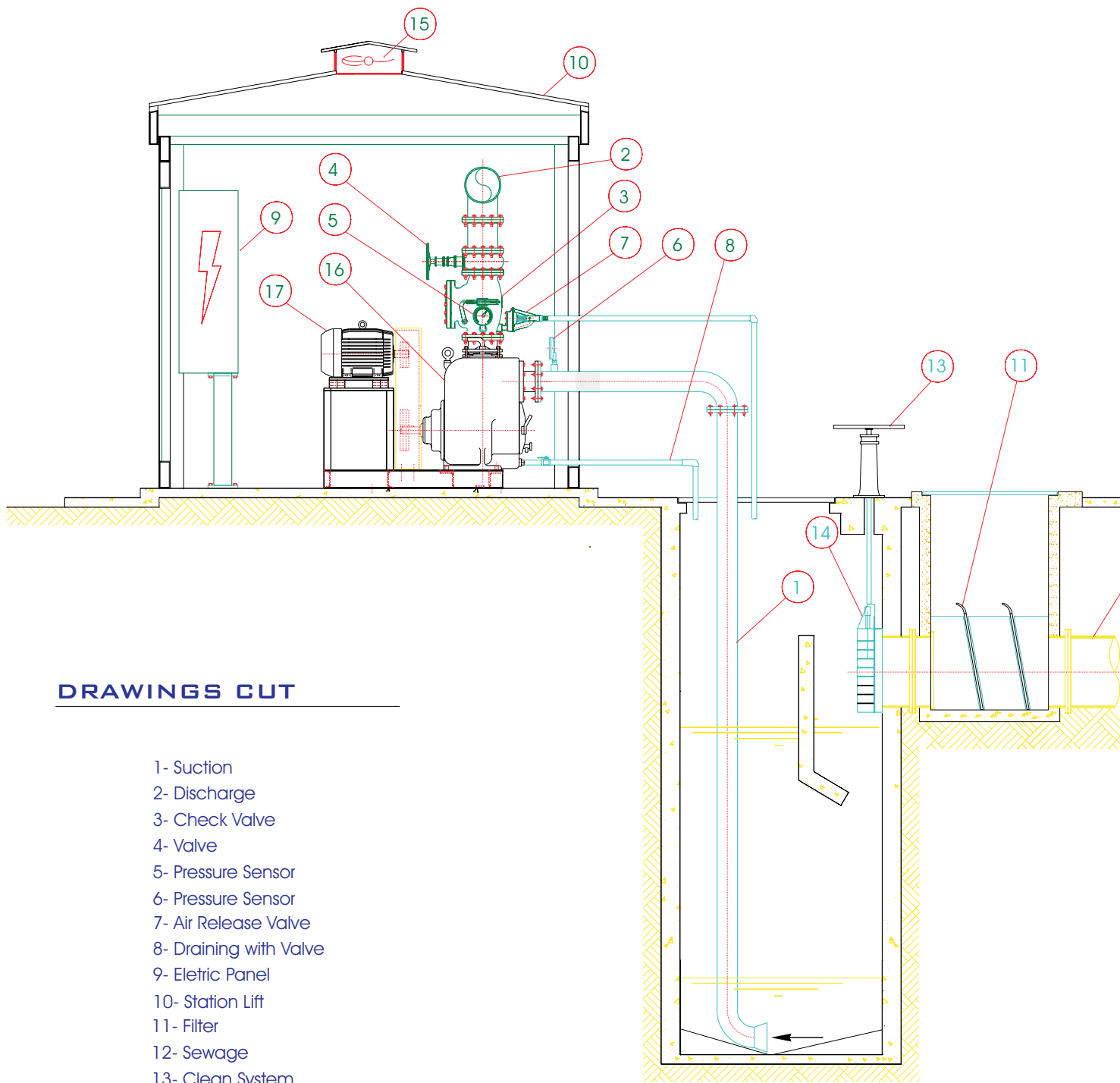

DRAWINGS CUT

- 1- Suction
- 2- Discharge
- 3- Check Valve
- 4- Valve
- 5- Pressure Sensor
- 6- Pressure Sensor
- 7- Air Release Valve
- 8- Draining with Valve
- 9- Electric Panel
- 10- Station Lift
- 11- Filter
- 12- Sewage
- 13- Clean System
- 14- Valve
- 15- Fan
- 16- Pump
- 17- Electric Motor