

FILL-RITE®

S Standard Duty
One Year Warranty

SD62 ROTARY PUMP

Owner's Operation & Safety Manual

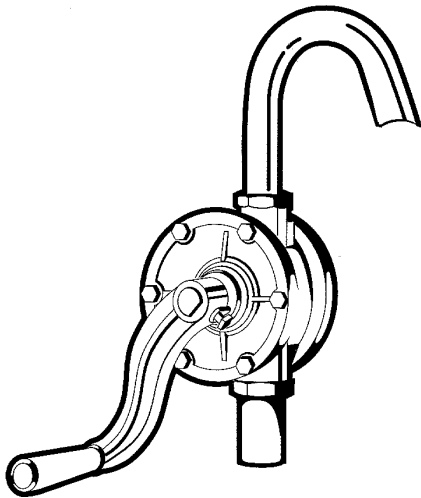

SAFETY INSTRUCTIONS

To ensure safe and efficient operation, it is essential to read and follow each of these warnings and precautions.

1. **Improper use or installation of this product can cause serious bodily injury or death.**
2. Do NOT smoke near pump or use pump near an open flame. Fire could result.



WARNING

This product should not be used for fluid transfer into aircraft. This product is not suited for use with fluids for human consumption or fluids containing water.

GENERAL DESCRIPTION

The Fill-Rite SD62 hand operated rotary vane transfer pump, with its smooth and easy turning handle, can deliver approximately 7.5 gallons of fluid per minute (100 revolutions).

TECHNICAL INFORMATION

Design Features:

- 1" NPT inlet, 1" O.D. discharge spout
- Heavy duty cast iron construction
- Smooth, easy action
- 2" NPT threaded bung adapter
- Suction pipe included

Fluid Compatibility

If in doubt about compatibility of a specific fluid, contact supplier of fluid to check for any adverse reactions to the following wetted materials:

- Cast Iron
- Galvanized Steel
- Neoprene

The SD62 is compatible with the following fluids:

- Diesel, Kerosene, Machine Oil, Fuel Oil, Agricultural Fluids, Detergents, Lube Oil, Noncorrosive Petroleum Products

DO NOT use the SD62 with the following fluids:

- Organic Solvents, Strong Alkalis, Strong Acids, Water

INSTALLATION

Use oil resistant pipe compound or teflon tape on all threaded joints.

1. Assemble suction pipe per exploded view of pump.
2. Slip barrel bung over suction pipe nipple.
3. Place assembly into tank or barrel and tighten bung adaptor mounting flange.
4. Screw pump inlet onto suction pipe nipple.
5. Set pump height by tightening bung adaptor clamp screw into suction pipe nipple.

OPERATING INSTRUCTIONS

1. Rotate handle several times clockwise, (direction indicated by arrow mark).
2. If a hose is attached to the outlet spout, liquid will be continuously delivered by siphon effect as long as there is a head between the liquid levels.
3. Siphon effect stops by turning the handle approximately 30°. Leakage in the hose joints will destroy the siphon effect. Use care to ensure good connections when attaching the hose.

REPAIR

Pumps needing repair should be taken to an authorized repair shop or returned to factory for service. Pumps must be thoroughly flushed before being returned for repair.

SD62 PUMP PARTS LIST			
ITM. NO.	PART NO.	DESCRIPTION	QTY.
1	SD62G8547	Pump Body	1

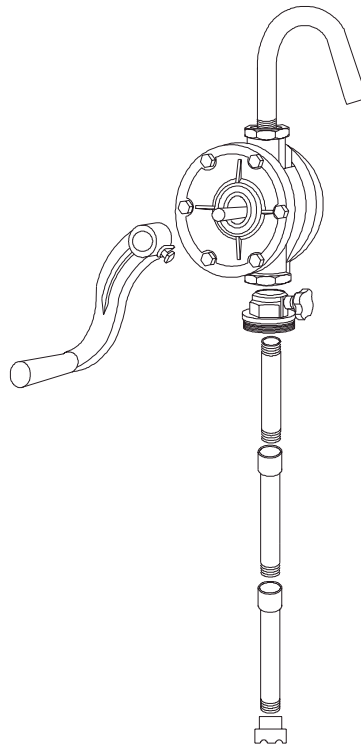

TROUBLESHOOTING GUIDE

	<u>POSSIBLE CAUSE</u>	<u>SOLUTION</u>
Pump will not prime	<ol style="list-style-type: none"> 1. Suction line problem 2. Vanes sticking 3. Gasket leakage 4. Excessive rotor or vane wear 	<p>Check for leaks in suction line</p> <p>Check vanes and slots for nicks, burrs or wear</p> <p>Tighten covers and joints</p> <p>Check rotor and vanes for excessive wear or damage</p>
Low pump capacity	<ol style="list-style-type: none"> 1. Suction line problem 2. Excessive rotor or vane wear 	<p>Check for leaks in suction line</p> <p>Check rotor and vanes for excessive wear or damage</p>
Pump fluid leakage	<ol style="list-style-type: none"> 1. Dirty Seal 2. Bad seal 3. Gasket leakage 	<p>Clean O-ring seal and seat area</p> <p>Replace seal</p> <p>Tighten covers and joints</p>

PRODUCT WARRANTY

Tuthill Transfer Systems ("Manufacturer") warrants to each consumer buyer of its Fill-Rite products (the "Buyer"), from the date of invoice or sales receipt, that goods of its manufacture ("Goods") will be free from defects of material and workmanship. Duration of this warranty is as follows:

- Heavy Duty Products - Two years
- Standard Duty Products – One year
- Economy Duty Products – One year
- Cabinet pumps, Parts, and Accessories -One year

Manufacturer's sole obligation under the foregoing warranties will be limited to either, at Manufacturer's option, replacing or repairing defective Goods (subject to limitations hereinafter provided) or refunding the purchase price for such Goods theretofore paid by the Buyer, and Buyer's exclusive remedy for breach of any such warranties will be enforcement of such obligations of Manufacturer. If Manufacturer so

requests the return of the Goods, the Goods will be redelivered to Manufacturer in accordance with Manufacturer's instructions F.O.B. Factory. The remedies contained herein shall constitute the sole recourse of the Buyer against Manufacturer for breach of warranty. IN NO EVENT SHALL MANUFACTURER'S LIABILITY ON ANY CLAIM FOR DAMAGES ARISING OUT OF THE MANUFACTURE SALE, DELIVERY OR USE OF THE GOODS EXCEED THE PURCHASE PRICE OF THE GOODS. The foregoing warranties will not extend to Goods subjected to misuse, neglect, accident or improper installation or maintenance, or which have been altered or repaired by anyone other than Manufacturer or its authorized representative. THE FOREGOING WARRANTIES ARE EXCLUSIVE AND IN LIEU OF ALL OTHER WARRANTIES OF MERCHANTABILITY, FITNESS FOR PURPOSE OF ANY OTHER TYPE, WHETHER EXPRESS OR IMPLIED. No person may vary the foregoing warranties and remedies except in writing signed by a duly authorized officer of Manufacturer. Warranties or remedies that differ from the foregoing shall not otherwise be binding on Manufacturer. The Buyer's acceptance of delivery of the Goods constitutes acceptance of the foregoing warranties and remedies, and all conditions and limitations thereof.



8825 Aviation Drive
 Fort Wayne, Indiana USA 46809
 Tel 260 747-7524 Fax 260 747-3159

FILL-RITE®

The Most Trusted Name in Pumps and Meters

**TOUGH
RELIABLE
LONG-LASTING
HAND PUMPS**



Ideal for use with drums and barrels in low volume applications.

As with all Fill-Rite® fuel transfer pumps, our hand pumps are tough, reliable and long lasting. Fill-Rite hand pumps are perfect for low volume transfer of gasoline*, light oils, diesel fuel and other fluids from drums and barrels. Depending on the style of pump you choose, they operate by piston, rotary or hand lever action.

*For use with the 100 and 5200 series only.

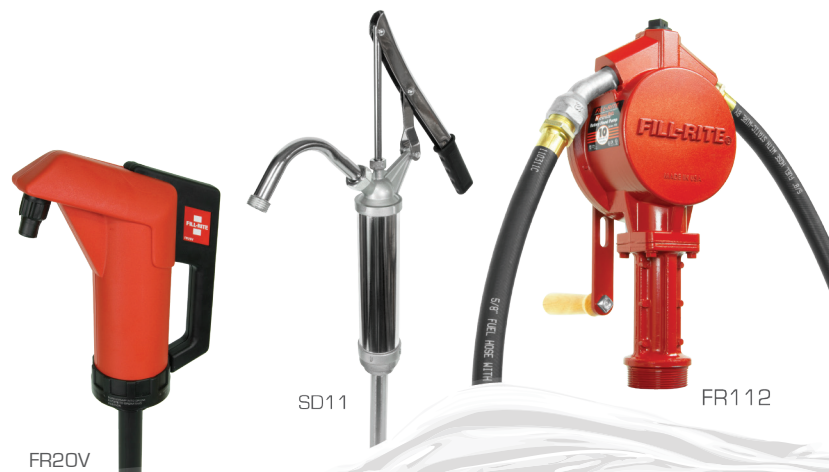

Models available for a wide variety of fluids including:

- Diesel Fuel
- Bio Diesel
- Gasoline*
- Motor Oil
- Automatic Transmission Fluid
- Hydraulic Oil
- And many other chemicals and light oils



5200 Piston Series · Heavy Duty

- 3' Lift
- For Drums, Totes, and Barrels
- Vacuum Breaker Included
- Cast Aluminum Housing Construction
- 2" NPT Bung Mount
- UL/cUL Certified

FR152	FR152	FR151	FR150
Flow Rate (GPM/LPM)	20 Gal (75L) / 100 Strokes	20 Gal (75L) / 100 Strokes	20 Gal (75L) / 100 Strokes
Inlet/Outlet	1" / 3/4"	1" / 3/4"	1" / 3/4"
Compatibility	Gasoline, Diesel Fuel, Light Oil, and Kerosene		
Included Accessories	20" - 34 3/4" Steel Telescoping Suction Pipe, 3/4" x 8' Hose, 3/4" Hose-end Spout	20" - 34 3/4" Steel Telescoping Suction Pipe, Pail Spout	Pump Only



100 Rotary Series · Heavy Duty

- 3' Lift
- For Drums, Totes, and Barrels
- Vacuum Breaker Included
- Cast Aluminum Housing Construction
- 2" NPT Bung Mount
- UL/cUL Certified

FR112C	FR112	FR112C	FR113
Flow Rate (GPM/LPM)	10 Gal (38 L) per 100 rev.	10 Gal (38 L) per 100 rev.	10 Gal (38 L) per 100 rev.
Inlet/Outlet	1" / 3/4"	1" / 3/4"	1" / 3/4"
Compatibility	Gasoline, Diesel Fuel, Light Oil, and Kerosene		
Included Accessories	20" - 34 3/4" Steel Telescoping Suction Pipe, 3/4" x 8' Hose, 3/4" Hose-end Spout	20" - 34 3/4" Steel Telescoping Suction Pipe, 3/4" x 8' Hose, 3/4" Hose-end Spout, Gallon Counter	20" - 34 3/4" Steel Telescoping Suction Pipe, Pail Spout



Special Use Pumps · Standard Duty

- For Drums, Totes, and Barrels
- Will Handle a range of automotive fluids (see compatible fluids below)
- 2" NPT Bung Mount

SD62	FR31	FR20V	SD62	SD11
Description	Quart Stroke Pump	Lever Piston	Rotary Pump	Lever Piston
Flow Rate	1 Quart (1 Liter) per Stroke	11 oz. per Stroke	7.5 Gal (28 L) / 100 Strokes	11 oz. per Stroke
Inlet/Outlet	1/2" / Spout	1" / Spout	3/4" / Spout	1" / Spout with Garden Hose Threads
Mats of Const - Housing	Cast Iron and Steel	Polypropylene	Cast Iron	Steel and Cast Aluminum
Compatibility	Gear and Lube Oil, Petroleum Products, and Anti-freeze	Light Oils, Anti-freeze, Hydraulic Oils, and Coolant	Diesel, Kerosene, Machine Oil, and Petroleum Products	Light Oils, ATF, Diesel Fuel, Hydraulic Fluid, and Kerosene
Included Accessories	23" - 40 1/2" Polypropylene Telescoping Suction Pipe	19 3/4" - 35 1/2" Polypropylene Telescoping Suction Pipe	3 Pieces of 13" Steel Suction Pipe	18 1/2" - 34 1/2" Steel Telescoping Suction Pipe and No-Drip Valve



Excellence at work. Excellence in life.

8825 Aviation Drive
Fort Wayne, Indiana 46809

P (800) 634-2695 or (260) 747-7524

F (800) 866-4861



FILLRITE.COM