



BOMBAS



CARRY

CARACTERÍSTICAS

- FÁCIL DE INSTALAR
- SEGURA DE MOVER
- APLICACIÓN DE LARGA DURACIÓN

La bomba PIUSI CARRY 3000 es una bomba de CC de transferencia de combustible diésel diseñada para satisfacer las necesidades de aquellos que buscan una bomba portátil de larga duración y gran calidad. La CARRY 3000 está equipada con una robusta asa que facilita el transporte y viene completa con tubo dispensador, cables de alimentación y pistola.

RENDIMIENTO

HASTA
70 L/MIN

CAUDAL

12/24 V

TENSIÓN
ALIMENTACIÓN

30 MIN

CICLO DE SERVICIO



CARRY PANTHER

CARRY



CARRY 3000 INLINE

EMBALAJE

CÓDIGO	PESO		EMBALAJE			N.º CAJAS/ EUROPALES	
	KG	LBS	MM	PULGADAS	UDS. /CAJA	✕	
FO022300C	4,2	9,3	260X235X164	-	1	84	120
FO022400C	4,2	9,3	260X235X164	-	1	84	120
FO0223260	4,2	9,3	260X235X164	-	1	84	120
FO0224240	4,2	9,3	260X235X164	-	1	84	120
FO034004B	4,2	9,3	260X235X164	-	1	84	120
FO034104C	4,2	9,3	260X235X164	-	1	84	120

GRÁFICO

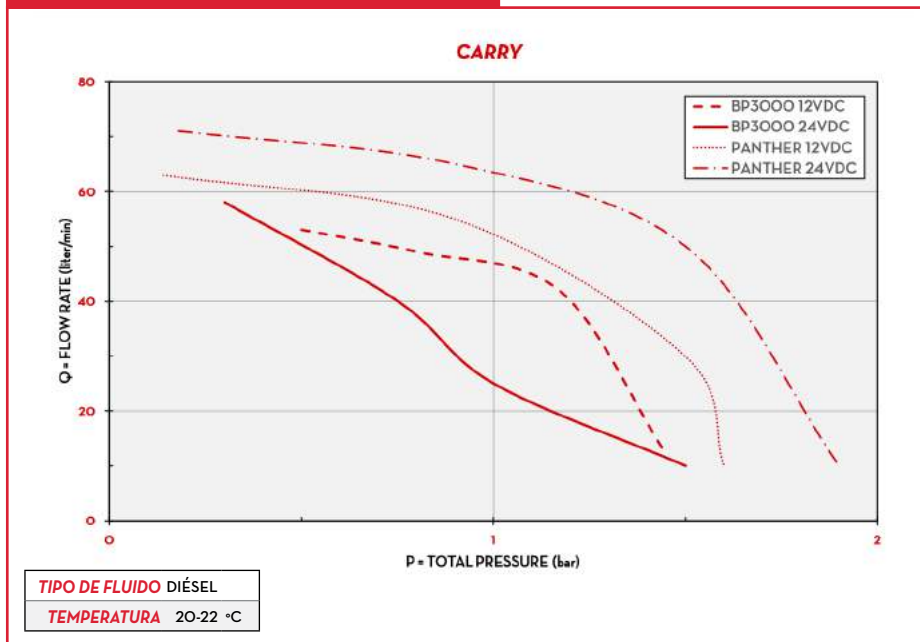

CONTENIDO DE LA CAJA

- BOMBA CARRY
- ASA
- TUBO DISPENSADOR
- CABLE ELÉCTRICO CON PINZAS
- CONEXIONES

DETALLES



DIMENSIONES

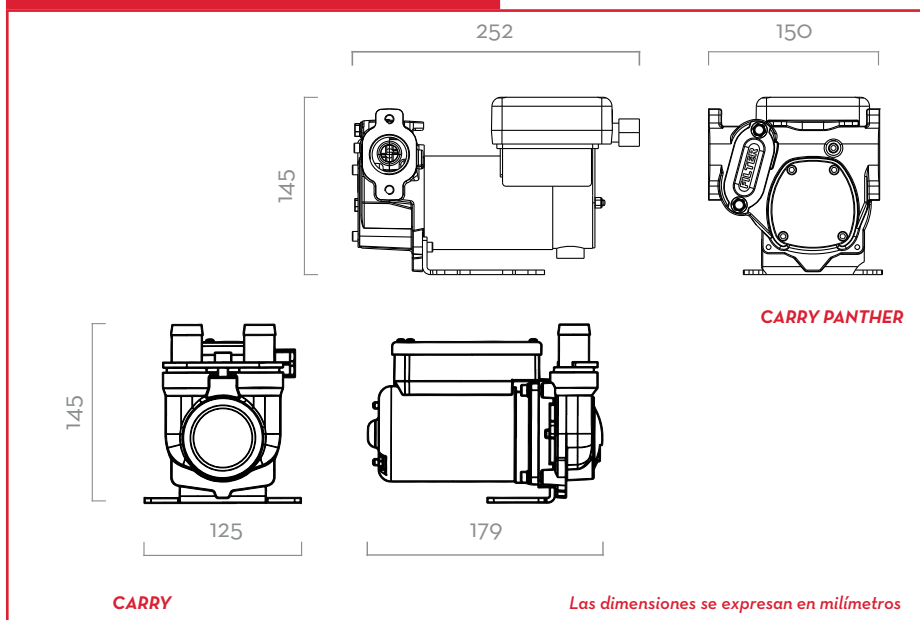

MATERIALES

- CUERPO: HIERRO FUNDIDO
- ROTOR: ACERO SINTERIZADO
- PALETAS: RESINA ACETÁLICA
- JUNTA: NBR
- EJE: ACERO

FICHA TÉCNICA

CÓDIGO	DESCRIPCIÓN	TIPO DE FLUIDO	CAUDAL		TENSIÓN			FUSIBLE	CICLO DE SERVICIO	RPM	PRESIÓN MÁX.	INTERRUPTOR ON/OFF	ENTRADA/SALIDA
			L/MIN	GPM	V CC	POTENCIA VATIOS	AMP. MÁX.						
FOO22300C	CARRY 3000 12V	D	50	13	12	300	24	25	30	2900	1,5	SÍ	-
FOO22400C	CARRY 3000 24V / 12V	D	50/30	13/6	24/12	310/80	13/6,5	15	30	2900/1500	1,5	SÍ	-
FOO223260	CARRY 3000 INLINE 12V	D	50	13	12	300	24	25	30	2900	1,5	SÍ	3/4"
FOO224240	CARRY 3000 INLINE 24V	D	50/30	13/6	24/12	310/80	24	15	30	2900/1500	1,5	SÍ	3/4"
FOO34004B	CARRY PANTHER 12V	D	56	15	12	420	13/6,5	-	30	2900	-	SÍ	1"
FOO34104C	CARRY PANTHER 12V / 24V	D	35/70	9/18	24/12	600/200	13/6,5	-	30	3500/1800	-	SÍ	1"